

# Technical Data S3

## Base machine

Specifications, speed, acceleration



ZS1-01-2018-m&k

### Specifications

repeatability <sup>1)</sup>	$\pm 0,03 \text{ mm}^* / \pm 0.001''^*$
position accuracy <sup>1)</sup>	$\pm 0,1 \text{ mm/m} / \pm 0.0012''/\text{ft} + \text{repeatability}^*$
floor load requirements	200 kg/m <sup>2</sup> / 45 lbs/ft <sup>2</sup>
interface	RS232C/V24, Ethernet 10/100Mbit
operating temperature	10 - 35 °C / 50-95 °F
relative humidity	10-80 % non condensing
noise emission	< 75 dB (depending on material and cutting technology)
max. material thickness	25 mm / 0.9"
max. material weight	10 kg/m <sup>2</sup> / 2 lbs/ft <sup>2</sup> (can affect the evenness of the working surface)
electrical requirements	3ph+N+GND, 208 V, 50/60 Hz, 20 A 3ph+N+GND, 400 V, 50/60 Hz, 16 A

### Speed, acceleration <sup>2)</sup>

max. speed X/Y-axis	1414 mm/s / 55"/s
max. acceleration X/Y-axis	14,1 m/s <sup>2</sup> / 555"/s <sup>2</sup>
max. speed Z-axis	500 mm/s / 20"/s
max. acceleration Z-axis	64 m/s <sup>2</sup> / 2520"/s <sup>2</sup>
max. rotation speed T-axis	110 rad/s
max. rotation acceleration T-axis	4602 rad/s <sup>2</sup>

1) X/Y drive system, static, at constant operating temperature (may vary depending on cutting tool/method).

2) Depending on cutter size, modules.

# Technical Data **S3**

## Base machine

Dimensions, weight, material

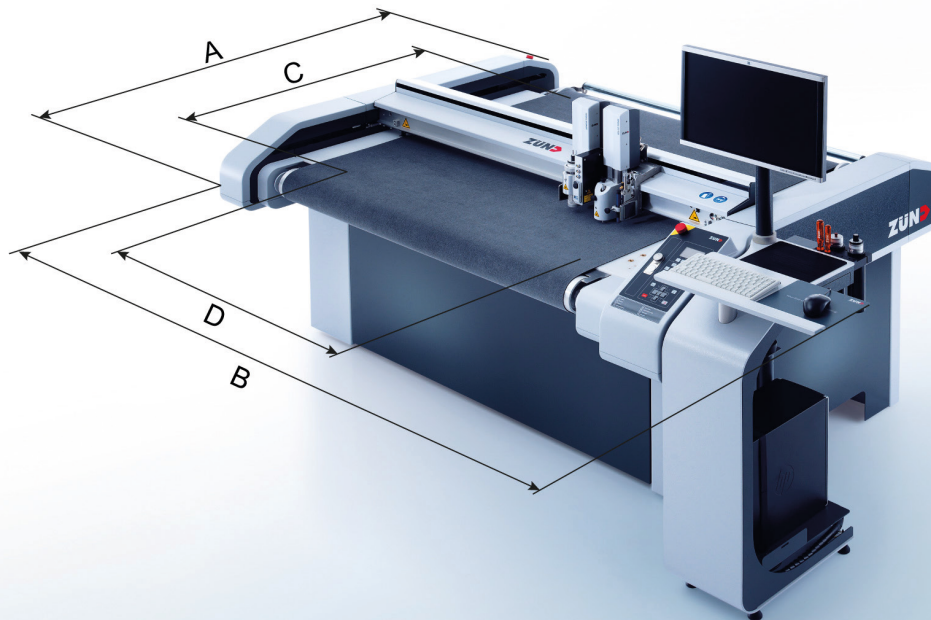

Type	Working area (C x D)	Overall dimensions, incl. workstation (A x B)	Machine weight
<b>M-800</b>	830 mm x 1330 mm / 32" x 52"	1540 mm x 2610 mm / 60" x 103"	420 kg / 925 lbs
<b>M-1200</b>	1230 mm x 1330 mm / 48" x 52"	1940 mm x 2610 mm / 76" x 103"	490 kg / 1080 lbs
<b>M-1600</b>	1630 mm x 1330 mm / 64" x 52"	2340 mm x 2610 mm / 92" x 103"	560 kg / 1235 lbs
<b>L-1200</b>	1230 mm x 1800 mm / 48" x 70"	1940 mm x 3080 mm / 76" x 121"	560 kg / 1235 lbs
<b>L-1600</b>	1630 mm x 1800 mm / 64" x 70"	2340 mm x 3080 mm / 92" x 121"	610 kg / 1345 lbs
<b>XL-1200</b>	1230 mm x 2270 mm / 48" x 89"	1940 mm x 3550 mm / 76" x 140"	620 kg / 1365 lbs

Type	max. materialwidth cutter with static work surface	max. materialwidth cutter with material transport
<b>M-series</b>	1580 mm / 62"	1330 mm / 52"
<b>L-series</b>	2050 mm / 80"	1800 mm / 70"
<b>XL-series</b>	2520 mm / 99"	2270 mm / 89"

**ERPA**   
Design | Print | Cut

ERPA Systeme GmbH  
Software- und Systemlösungen  
für die Verpackungsindustrie  
Willi-Eichler-Str. 24  
37079 Göttingen  
Germany



shop.erpa.de  
Unser  
Onlineshop



Wir auf  
Facebook

Telefon +49 (0) 551-789 50-0  
info@erpa.de | www.erpa.de

Technical data subject to change without notice.

**Zünd Systemtechnik AG**

Industriestrasse 8 · CH-9450 Altstätten · T +41 71 757 81 00 · info@zund.com · www.zund.com

**ZÜND**   
swiss cutting systems