

Solid reasons for Zünd D3



Zünd

Zünd Systemtechnik AG - family-owned and based in Switzerland - specializes in digital cutting systems. The Zünd name represents Swiss quality and has become synonymous with precision, performance and reliability. Since 1984 we have been designing, producing and marketing modular cutting systems and have gained a global reputation as market leader. The technological superiority of our products stems from our insistence on high quality standards, modular design and focus on our customers.

Modularity

Zünd cutting systems are based on a design concept that lends them greater flexibility and adaptability than any others on the market can offer. This unique modularity makes it possible to cost-effectively configure and upgrade Zünd cutters for ever-changing cutting needs. This contributes to their exceptional ROI and makes them retain their value over many years.

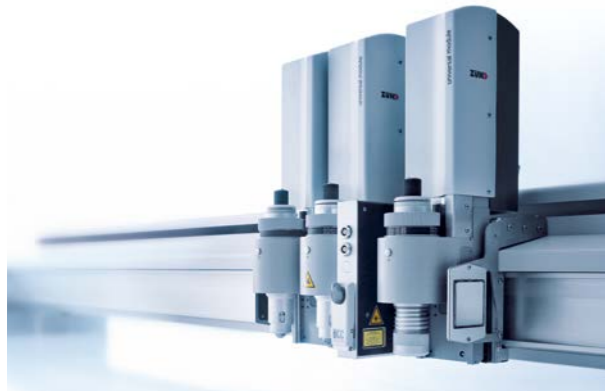

Profitability

Solid performance, outstanding quality - thousands of Zünd cutting systems worldwide are producing non-stop and offer daily proof of their unparalleled profitability. Innovative technology and superior standards of construction guarantee low maintenance costs. Outstanding energy efficiency is yet another benefit of our products. Optimal processing methods, state-of-the-art vacuum generators and sophisticated material-advance systems keep energy demands low and contribute to the eco-friendliness and sustainability of our products.

Worldwide service

What applies to our cutting systems, also applies to our service: Exceptional performance, precision and reliability. Optimally trained and highly experienced specialists are always at your disposal. Zünd technicians all over the world are only a phone call away. Our subsidiaries and distribution partners in your vicinity strive to keep response times to a minimum and are ready to provide support whenever the need arises.



D3 digital cutting systems Choice of sizes

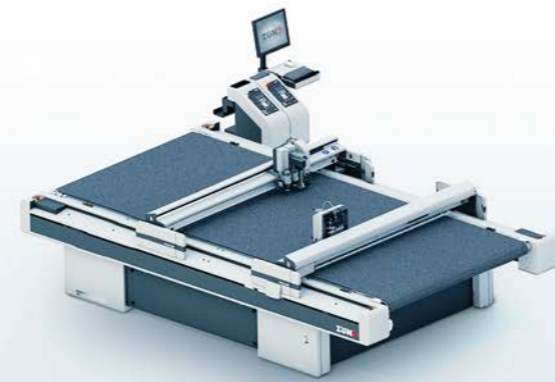

D3 L-3200
1800 mm x 3200 mm

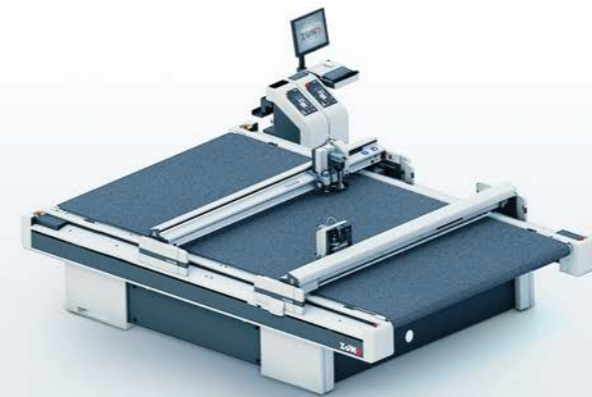

D3 XL-3200
2270 mm x 3200 mm

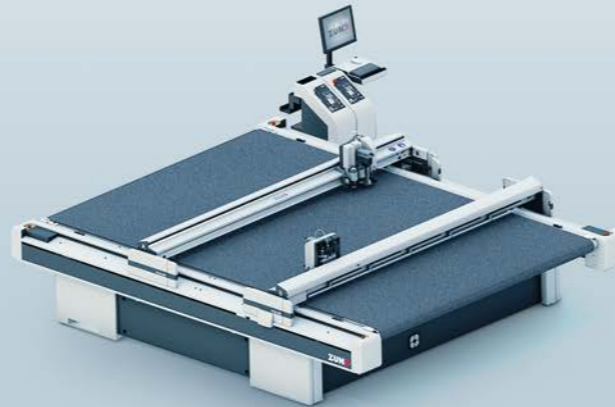

D3 2XL-3200
2740 mm x 3200 mm

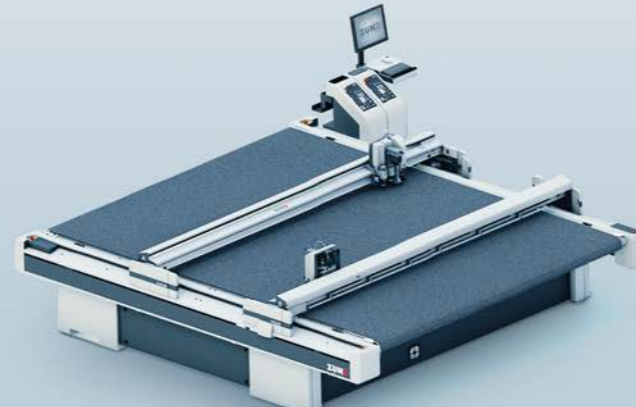

D3 3XL-3200
3210 mm x 3200 mm

Technical Overview D3 Digital Cutter

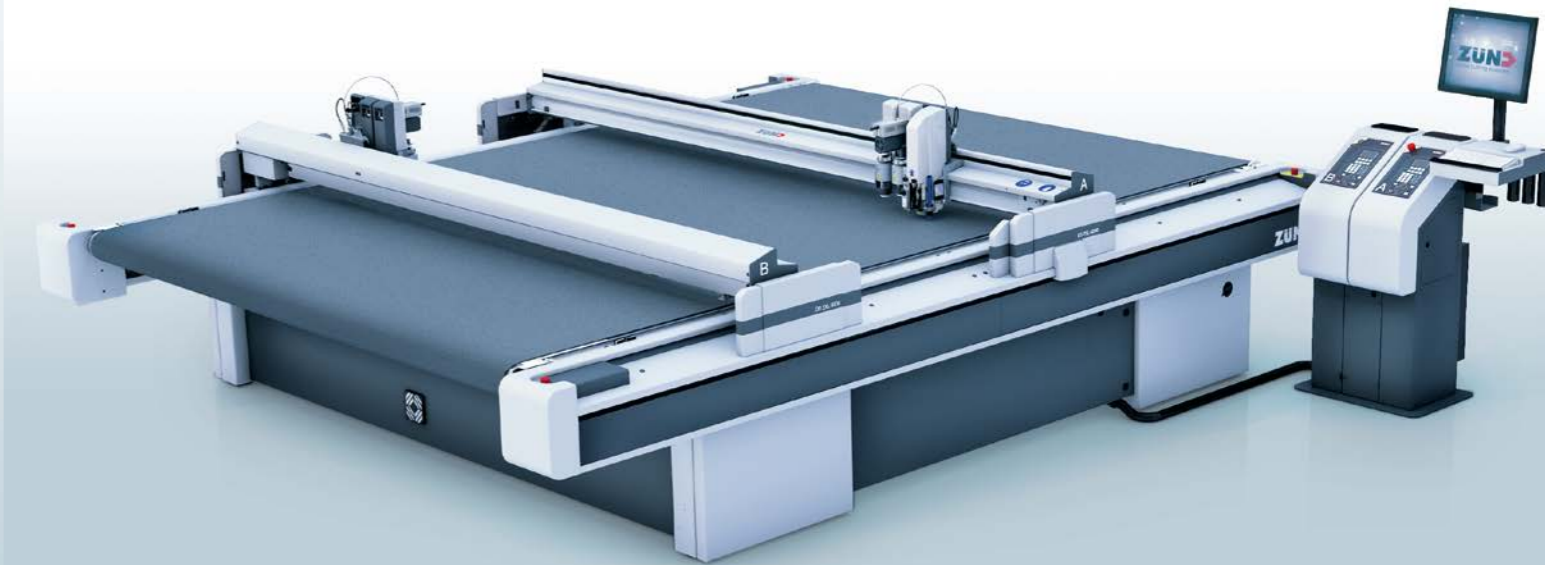

12/2017

ERPA
Design | Print | Cut

ERPA Systeme GmbH
Software- und Systemlösungen
für die Verpackungsindustrie
Willi-Eichler-Str. 24
37079 Göttingen
Germany



shop.erpa.de
Unser
Onlineshop

Telefon +49 (0) 551-78950-0
info@erpa.de | www.erpa.de



Wir auf
Facebook

Zünd Systemtechnik AG
Industriestrasse 8
CH-9450 Altstätten
T +41 71 757 81 00
info@zund.com
www.zund.com

ZÜND
swiss cutting systems

Your first choice in digital cutting.

ZÜND
swiss cutting systems

D3 cutter systems

Perfection in every detail

Flexible tool configuration

The tried and tested modular tool system is available on both beams of the D3. Define which functions your cutter has to fulfill and configure your individual tool combination from the Zünd modular system.

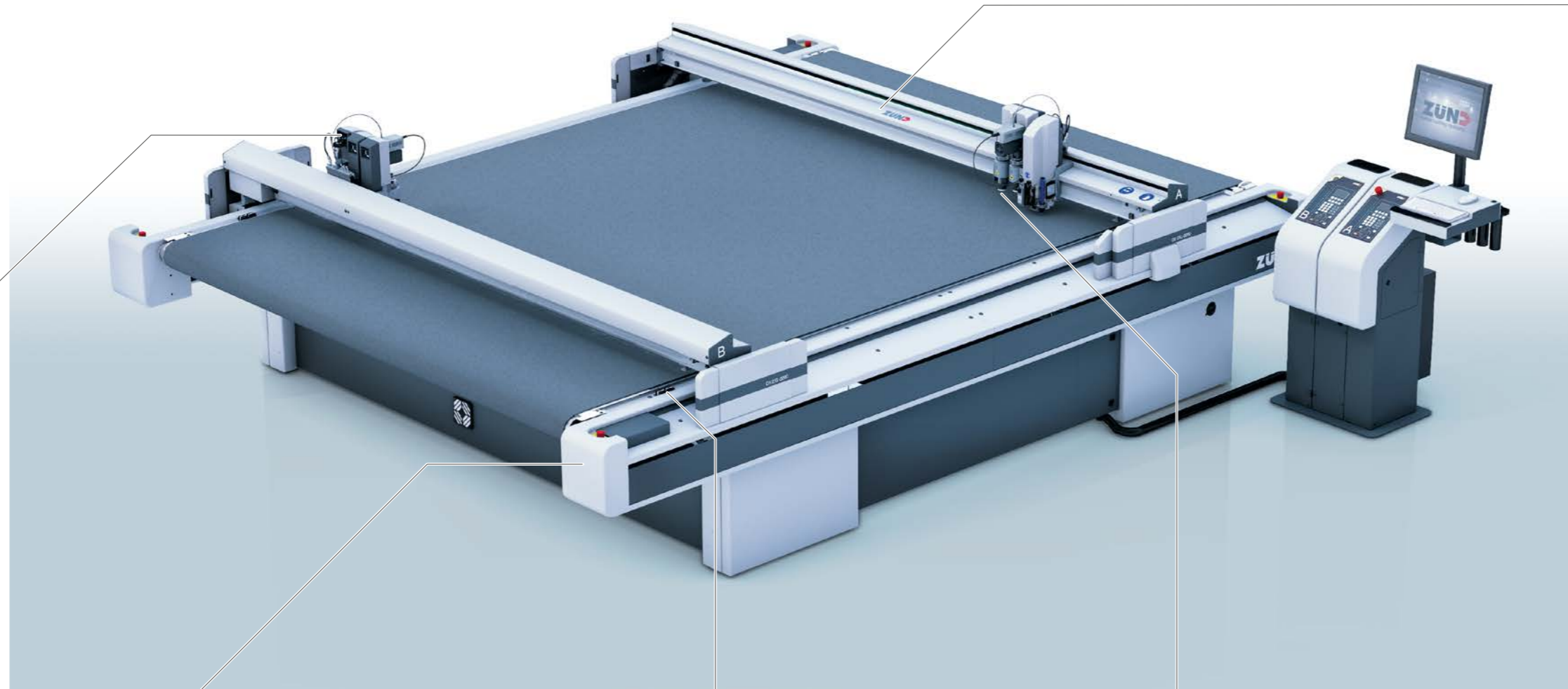

Double beams for maximum productivity

Depending on the job, the throughput can be doubled by using two beams that work independently of each other. The intelligent cutter controller allocates the work optimally between the two beams and thus ensures the highest possible productivity.

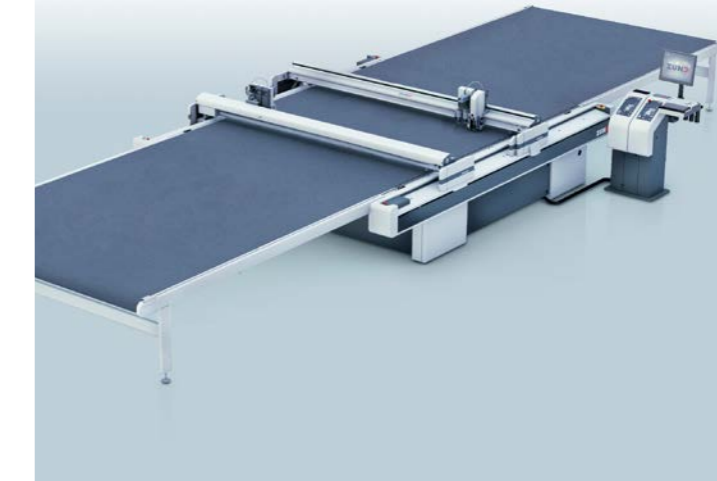

Ergonomics and handling

The D3 can be individually automated with cutter extensions and various material handling systems. This significantly increases the productivity of the cutter and manual activities are reduced to a minimum. The ergonomic design of the Zünd cutter simplifies the operator's work, which increases efficiency even further.

Efficient tool management

Zünd's distinctive modular design allows you to configure the required tooling in a few quick, easy steps. The resulting flexibility lets you react instantaneously to changes in production requirements, saving you both time and money.

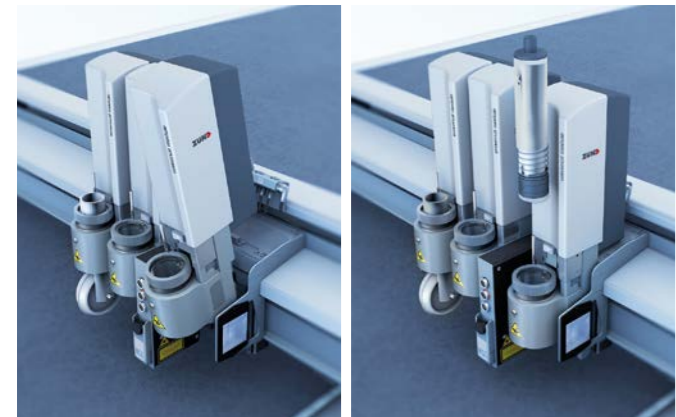

Powerful and robust

Zünd high-performance cutters are made for shift operation. Which is why only robust and high-quality components are used. This is demonstrated in the excellent quality, highest reliability, and strong performance.



Integrated tool initialization

Quick, precise, time-saving: the setting of knives, routers, and creasing wheels takes place via the fully automatic initialization system. Manual adjustment work to determine the cutting depth is no longer necessary.



Precision in every detail

Zünd cutters are high-precision machines. All components – from drive system to cutting blade – are designed and manufactured to work together perfectly. This lets you produce efficiently and wow your customers with perfect results.



Fully automated production - BHS

High volume, high quality and flexibility - with the Zünd Board Handling System, you can run 24/7 non-stop production with minimal personnel! Fully automated board loading and unloading limits the necessary labor to bringing in/removing pallets of stacked uncut/cut media.

