

Technical Data D3

Base machine

Specifications, speed, acceleration

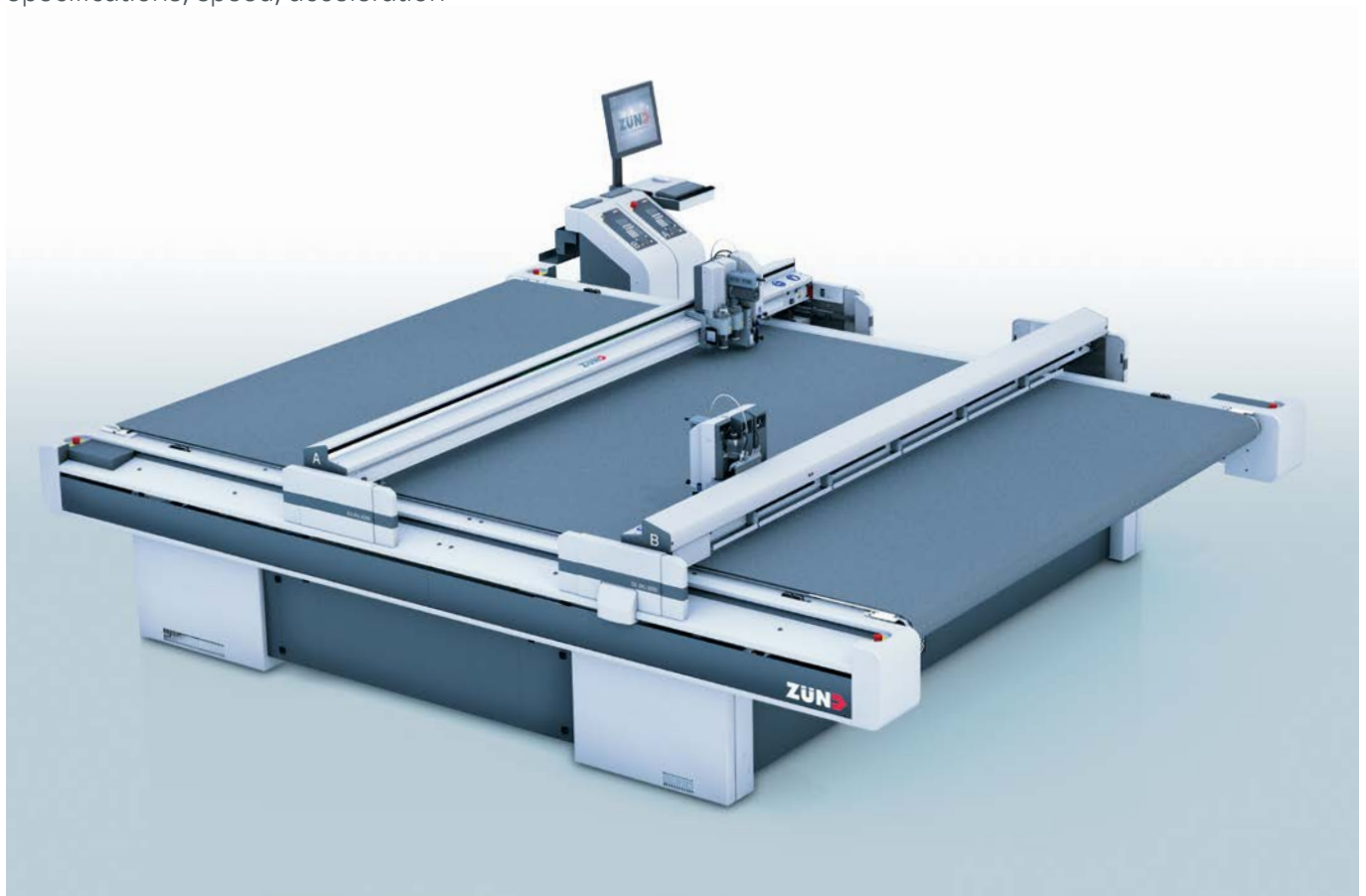

ZST-03-2016-m&k

Specifications

repeatability ¹⁾	$\pm 0,03 \text{ mm} / \pm 0.001''$
position accuracy ¹⁾	$\pm 0,1 \text{ mm/m} / \pm 0.0012''/\text{ft} + \text{repeatability}$
floor load requirements	200 kg/m ² / 45 lbs/ft ²
interface	2x Ethernet 10/100Mbit
operating temperature	10-35 °C / 50-95 °F
relative humidity	10-80 % non condensing
noise emission	< 75 dB (depending on material/cutting technology)
beam height	60 mm / 2.3''
electrical requirements	AC 3ph+N+GND, 208/400 V, 50/60 Hz, 32 A
max. material weight	30 kg/m ² / 6 lbs/ft ² (manual loading) (can affect the evenness of the working surface)

Speed, acceleration ²⁾

max. speed X/Y-axis	1414 mm/s / 55''/s
max. acceleration X/Y-axis	9,3 m/s ² / 366''/s ²
max. speed Z-axis	500 mm/s / 20''/s
max. acceleration Z-axis	10 m/s ² / 393''/s ²
max. rotation speed T-axis	44.2 rad/s
max. rotation acceleration T-axis	3068 rad/s ²

- 1) X/Y drive system, static, at constant operating temperature (may vary depending on cutting tool/method).
- 2) Depending on cutter size, modules.

Technical Data D3

Base machine

Dimensions, weight, material

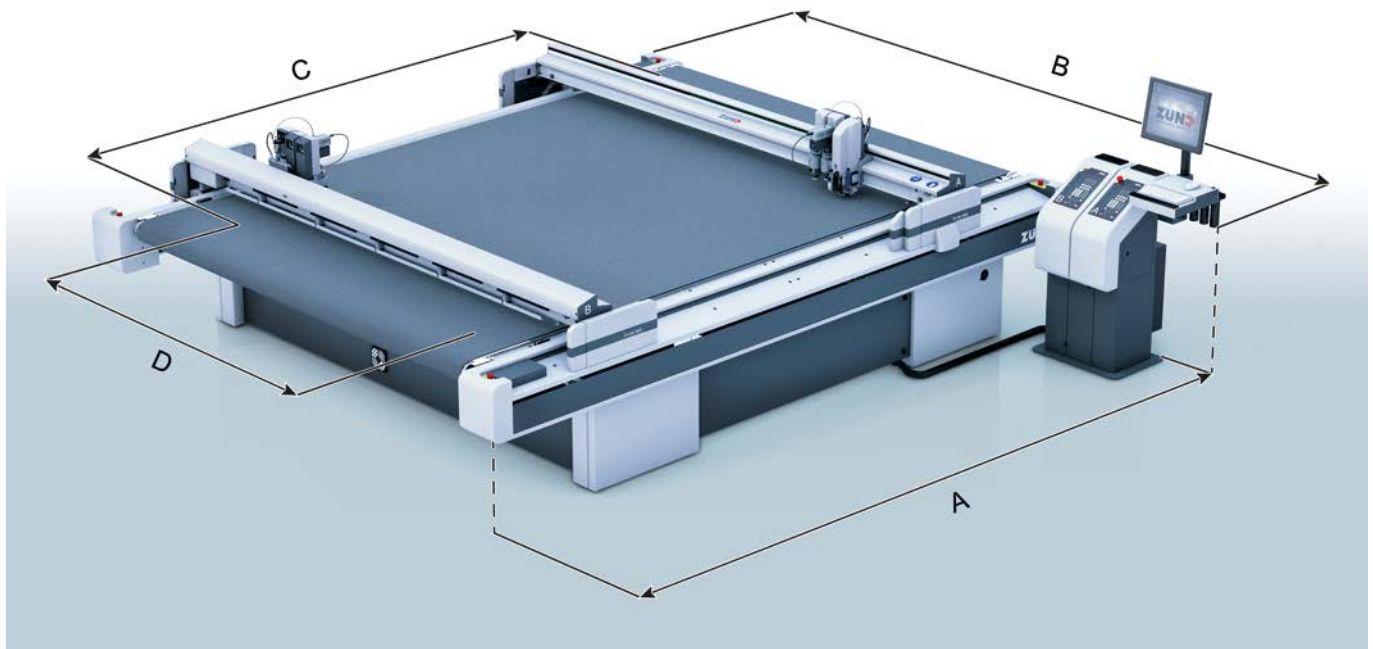

Type	Working area (C x D)	Overall dimensions, incl. workstation (A x B)	max. Materialwidth	Machine weight
L-3200	3200 mm × 1800 mm 125" × 70"	4480 mm × 3610 mm 176" x 142"	1800 mm 70"	1290 kg 2835 lbs
XL-3200	3200 mm × 2270 mm 125" × 89"	4480 mm × 4080 mm 176" x 161"	2270 mm 89"	1460 kg 3220 lbs
2XL-3200	3200 mm × 2740 mm 125" × 107"	4480 mm × 4550 mm 176" x 179"	2740 mm 107"	1600 kg 3530 lbs
3XL-3200	3200 mm × 3210 mm 125" × 126"	4480 mm × 5020 mm 176" x 198"	3210 mm 126"	1800 kg 3960 lbs

Technical data subject to change without notice.

ERPA
Design | Print | Cut

ERPA Systeme GmbH
Software- und Systemlösungen
für die Verpackungsindustrie
Willi-Eichler-Str. 24
37079 Göttingen
Germany



shop.erpa.de
Unser
Onlineshop



Wir auf
Facebook

Telefon +49(0)551-78950-0
info@erpa.de | www.erpa.de

Headquarters

Zünd Systemtechnik AG

Industriestrasse 8 · CH-9450 Altstätten · T +41 71 757 81 00 · F +41 71 757 81 11 · info@zund.com · www.zund.com

ZÜND
swiss cutting systems