

Technical Data BHS

Board Feeder and Board Stacker

Load capacity, electrical supply, pneumatics

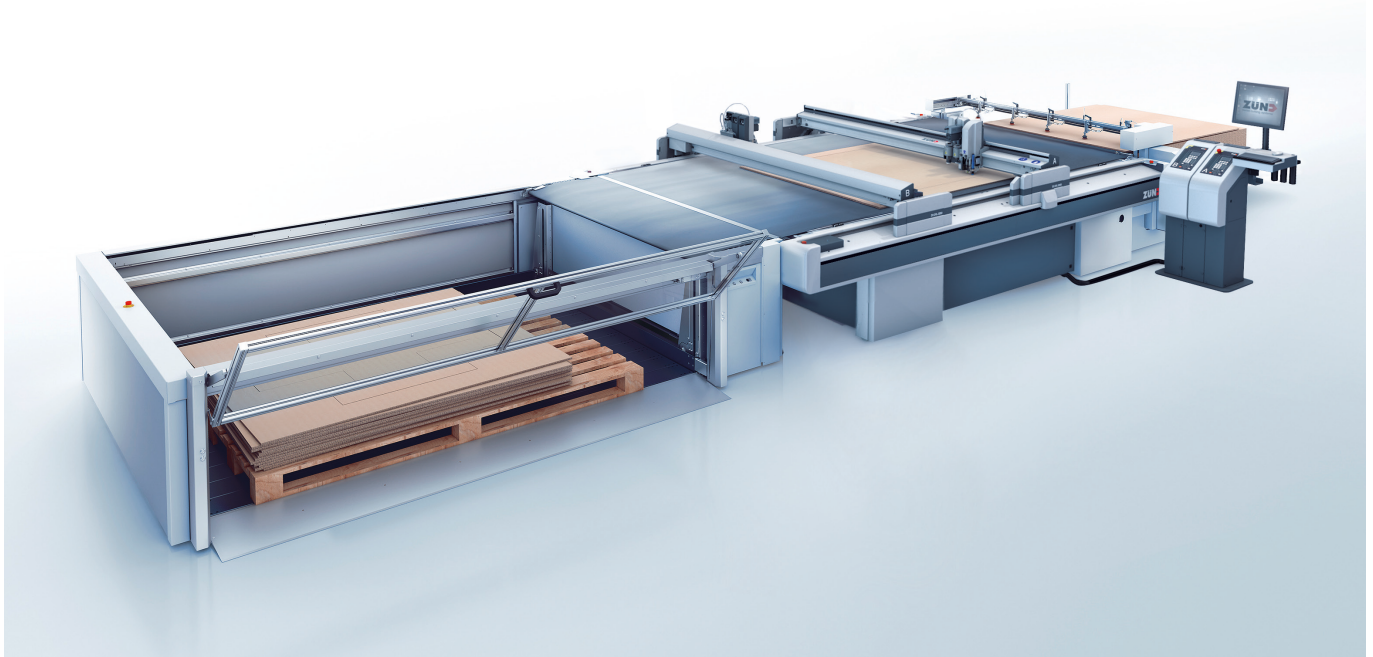

Load capacity	L-series	XL-series	2XL-series
max. panel size	3200 x 1620 mm	3200 x 2090 mm	3200 x 2560 mm
min. panel size	1000 x 700 mm	1000 x 700 mm	1000 x 700 mm
max. panel thickness	16 mm	16 mm	16 mm
min. panel thickness	1.5 mm	1.5 mm	1.5 mm
max. panel weight/pcs	15 kg	15 kg	15 kg
max. stack height feeder	540 mm	540 mm	540 mm
max. stack height stacker	500 mm	500 mm	500 mm
stack evenness	30 mm	30 mm	30 mm
max. centric load	800 kg	800 kg	800 kg
max. eccentric load	200 kg	200 kg	150 kg

Electrical supply	Stacker, Feeder
voltage	3-phase, 400 V, L1, L2, L3, N, PE 3-phase, 200 V, L1, L2, L3, N, PE
mains frequency	50/60 Hz
mains fuse	min. 16 A
fault-current circuit breaker	30 mA

Pneumatics	Stacker	Feeder
air pressure	Air is supplied by the cutter	0.6 MPa
Air flow	Air is supplied by the cutter	50 l/min
air pressure separating assistance	-	0.2 - 0.6 MPa
air flow separating assistance	-	25 - 50 l/min

Technical data subject to change without notice.

Technical Data BHS

Board Feeder and Board Stacker

Dimensions, weight

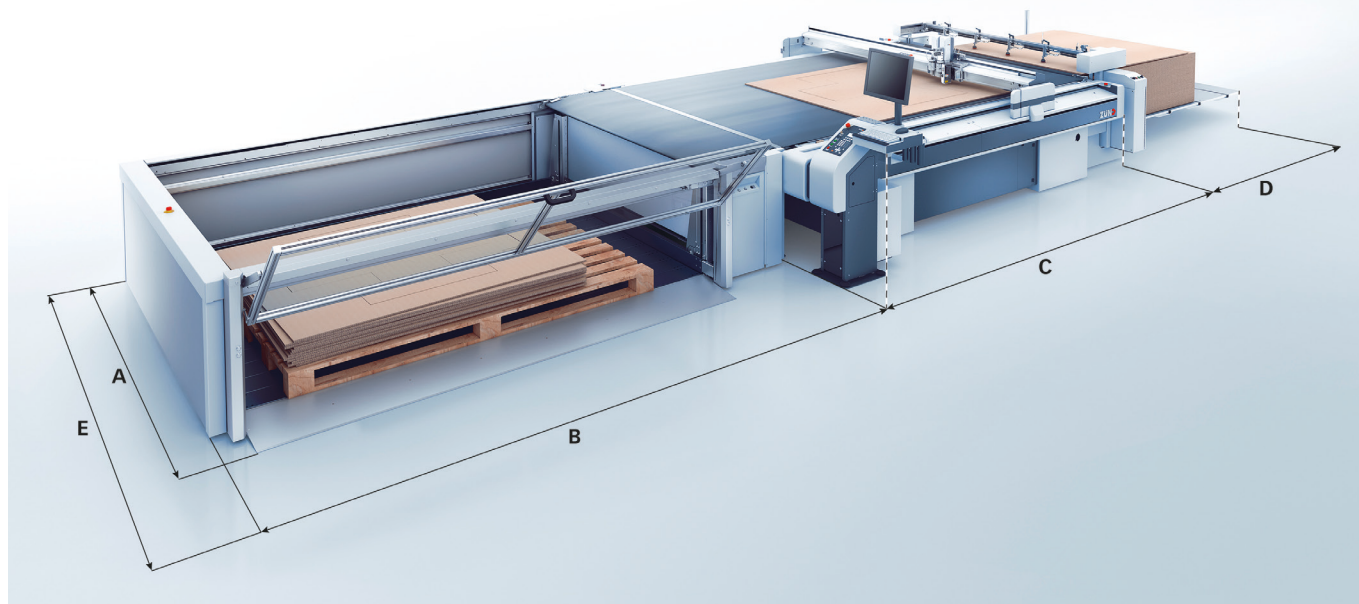

Dimensions Feeder	L-series	XL-series	2XL-series
Length (D)	3040 mm	3040 mm	3040 mm
Width (A)	2410 mm	2880 mm	3350 mm
Weight	630 kg	670 kg	720 kg

Dimensions Stacker	L-series	XL-series
Length (B)	4052 mm	4052 mm
Width (A)	2520 mm	2990 mm
Weight	880 kg	950 kg

Dimensions BHS incl. G3 Cutter	L-series	XL-series	2XL-series ¹⁾
Length (B+C+D)	11210 mm	11210 mm	7160 mm
Width (E)	3150 mm	3620 mm	4090 mm

Dimensions BHS incl. D3 Cutter	L-series	XL-series	2XL-series ¹⁾
Länge (B+C+D)	11390 mm	11390 mm	7340 mm
Breite (E)	3608 mm	4078 mm	4548 mm

ERPA
Design | Print | Cut

ERPA Systeme GmbH
Software- und Systemlösungen
für die Verpackungsindustrie
Willi-Eichler-Str. 24
37079 Göttingen
Germany



shop.erpa.de
Unser
Onlineshop



Wir auf
Facebook

Telefon +49(0)551-789 50-0
info@erpa.de | www.erpa.de

¹⁾ The stacker is not available for 2XL-cutters.
Technical data subject to change without notice.

Headquarters

Zünd Systemtechnik AG

Industriestrasse 8 · CH-9450 Altstätten · T +41 71 757 81 00 · F +41 71 757 81 11 · info@zund.com · www.zund.com

ZÜND
swiss cutting systems